

Propriedade da WEG-CESTARI. Proibida a reprodução ou uso sem autorização prévia.
 Property of WEG-CESTARI. Prohibited reproduction or use without previous authorization.
 Propriedad WEG-CESTARI. Prohibida la reproducción o uso sin permiso.

Posição de Montagem.
 (Visto eixo de Entrada)
 Mounting Position
 (View input shaft)
 Posición de Montaje
 (Visto eje de entrada)

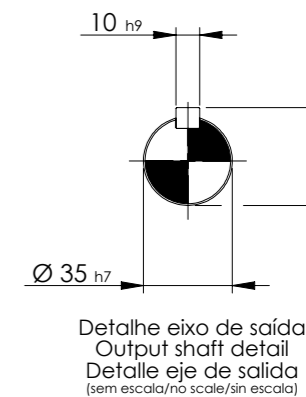
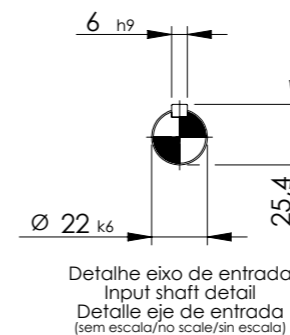
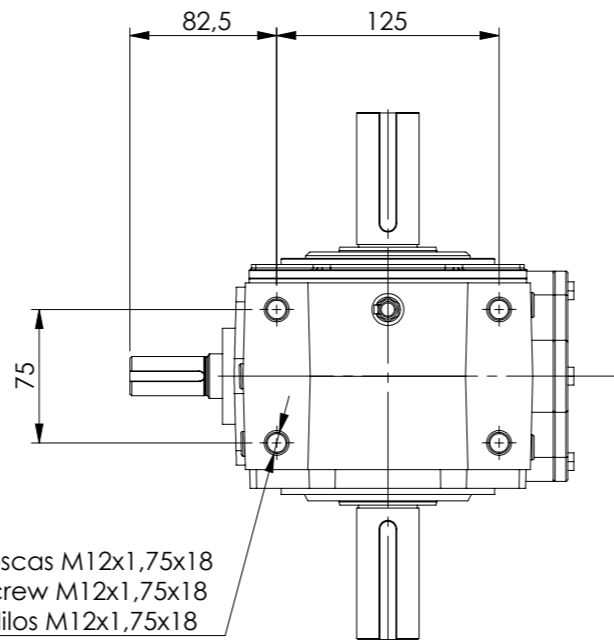
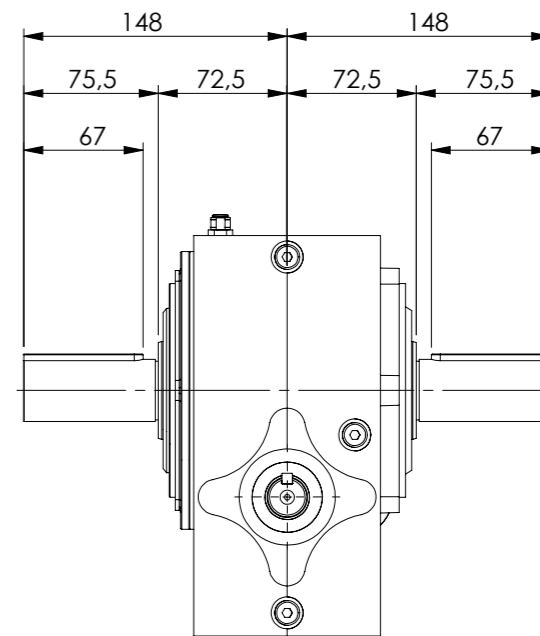
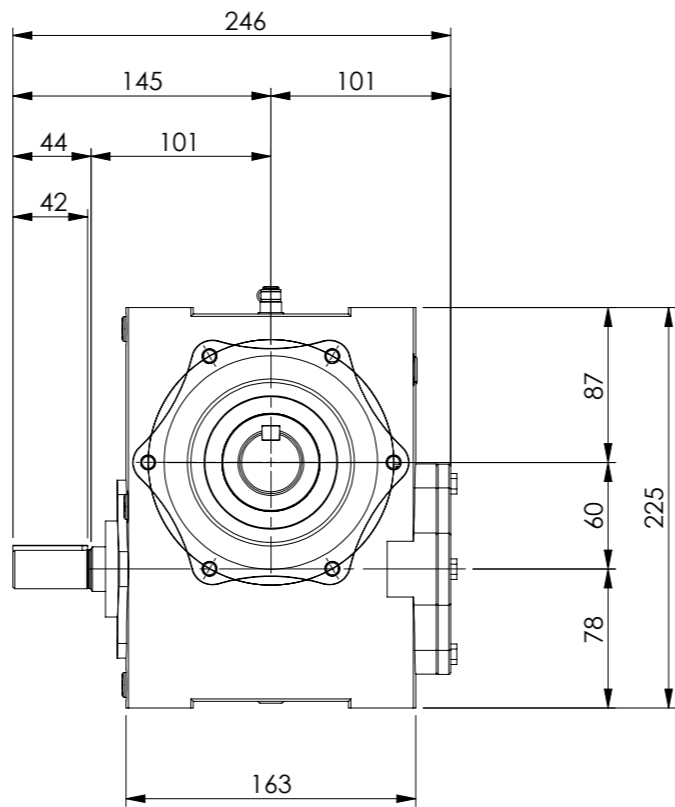
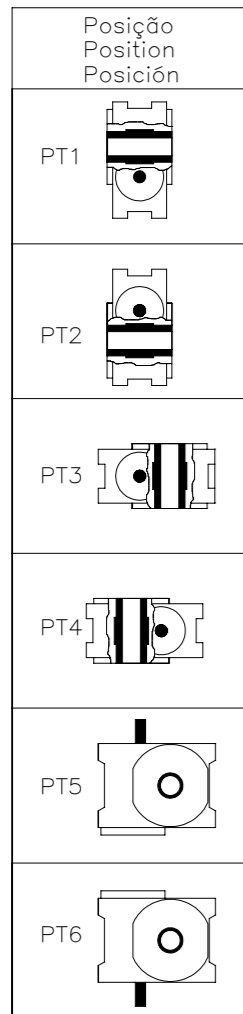

*Dimensões em mm/Dimensions in mm/Dimensiones en mm

Nota / Note / Nota:

Desenho representado na posição 1 (outras posições ver tabela).
 The drawing is represented at mounting position 1 (for other positions please see table).
 Diseño representado en la posición 1 (otras posiciones consulte la tabla).

DESENHO PARA ORÇAMENTO
PRELIMINARY DRAWING
DIBUJO PRELIMINAR

As dimensões informadas são orientativas, podendo ser alteradas sem prévio aviso, não devendo ser utilizado em projetos.

The dimensions in this drawing are indicative and may be modified without notice, and should not be used in final projects.

Las dimensiones de este dibujo son orientativas y pueden ser modificados sin previo aviso, y no deben utilizarse en los proyectos.

Denominação
 Name
 Denominación

DIMENSIONAL MAGMA M06



Escala/Scale/Escala
 1:4.25

Desenho N°
 Drawing N°
 Diseño N°

M0612001D00001_A0

Versão-0